

DOME CAMERA

TDC-32327QSD5, TDC-32327QFD5

MINI VANDAL DOME CAMERA



TDC-32327QSD5
Surface Mount Type



TDC-32327QFD5
Flush Mount Type

- FEATURES -

- 1/3" SONY High-Resolution Super HAD CCD
- 540TV Lines Horizontal Resolution
- Excellent Low Light Sensitivity of 0.3Lux/F1.2
- Auto White Balance
- Auto Gain Control
- Board Lens f=3.6mm
- Vandal Proof Dome Type
- IP66 Weatherproof Type
- Compact Design



1/3 SONY
SUPER HAD CCD



COLOR



BOARD LENS



IP 66



VANDAL PROOF



DC 12V

- DIMENSION -

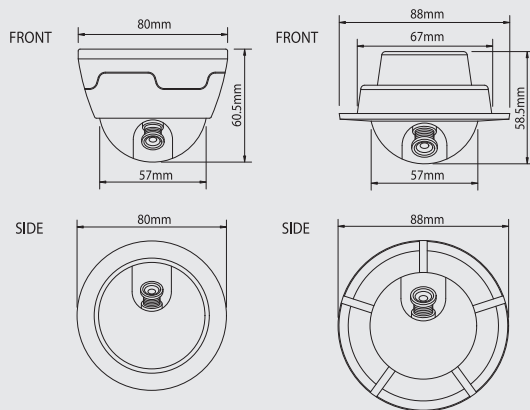

- CONNECTION -

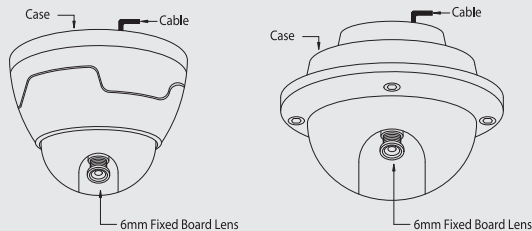

- SPECIFICATIONS -

TDC-32327QSD5 / TDC-32327QFD5		
Signal Format	NTSC	PAL
Horizontal Resolution	540TV Lines	
Image Sensor	1/3" SONY High-Resolution Super HAD CCD	
Effective Pixels	768(H) x 494(V)	752(H) x 582(V)
Scanning System	2:1 Interlace	
Synchronization	Internal	
Scanning Frequency	15.734 KHz(H), 59.94 Hz(V)	15.625 KHz(H), 50.00 Hz(V)
Video Output	CVBS : 1.0Vp-p/75Ω	
Min. Illumination	0.3Lux/F1.2	
Electronic Shutter	1/60 ~ 1/100,000 sec	1/50 ~ 1/100,000 sec
IRIS Control	MANUAL	
Signal to Noise Ratio	48dB or more (AGC Off)	
Backlight Compensation	BLC / FLC (SW)	
White Balance	AUTO	
Gain Control	AUTO	
Gamma	0.45	
Lens	Board Lens f=3.6mm (Option : 4.0 / 6.0 / 8.0 / 12.0mm)	
Input Voltage	DC 12V (±10%)	
Power Consumption	Max. 1.4W	
Operating Temperature	-10°C ~ +60°C	
Storage Temperature	-20°C ~ +70°C	
Operating Humidity	Under 85% Non-condensing	
Storage Humidity	Under 90% Non-condensing	
Dimension	TDC-32327QSD5 : 80.0(Ø) x 60.5(H)mm TDC-32327QFD5 : 88.0(Ø) x 58.5(H)mm	
Weight	TDC-32327QSD5 : Approx. 250g TDC-32327QFD5 : Approx. 190g	