

TEM-S72HV, TEM-S72HVX

IP66 72PCS IR LED B/W CAMERA



IP66



- FEATURES -

- 1/3" SONY DSP Super HAD High-Resolution B/W CCD
- 600TV Lines Horizontal Resolution
- 72pcs IR LED for night vision
- Visibility Range : 40~50m
- Varifocal Lens : 4.0~9.0mm/F1.6
- IP 66 Weatherproof Type
- Adjustable Lens without opening case
- Concealed Bracket (Cable Built in the bracket)

* TEM-S72HVX : EX-View



1/3 SONY DSP Super HAD CCD



B/W



4.0~9.0mm VARI-FOCAL LENS



72pcs IR LED



IP-66



DC 12V

- DIMENSION -

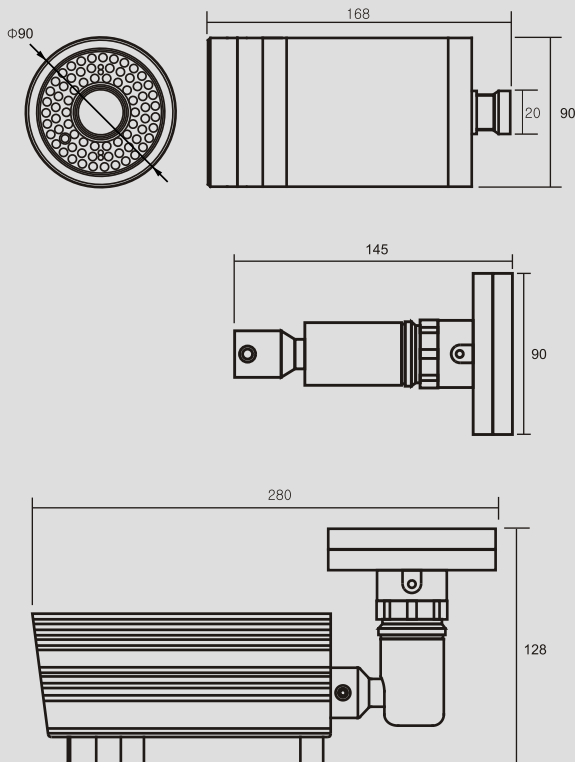

- SPECIFICATIONS -

TEM-S72HV / TEM-S72HVX		
Signal Format	EIA	CCIR
Horizontal Resolution	600TV Lines	
Image Sensor	TEM-S72HV : 1/3" SONY DSP Super HAD B/W CCD TEM-S72HVX : 1/3" SONY EX-View CCD	
Scanning System	525 lines interlaced	625 lines interlaced
Synchronization	Internal	
Video Output	CVBS : 1.0Vp-p/75Ω	
Min. Illumination	3Lux IR LED On	
Signal to Noise Ratio	45 dB or more (AGC Off)	
Gamma	0.45	
AGC	On	
Input Voltage	DC 12V (±10%)	
Power Consumption	LED Off : Max 2.4W, LED On : Max 9.6W	
Operating Temperature	-10°C to +55°C	
Storage Temperature	-20°C to +70°C	
Operating Humidity	Under 90% Non-condensing	
Storage Humidity	Under 90% Non-condensing	
Lens	DC Varifocal Lens : 4.0~9.0mm/F1.6	
Dimension	90(Φ) x 168(H)mm	
Weight	Approx. 1.3Kg	