

COVERT CAMERA

THM-3232HX

COVERT CCTV CAMERA



- FEATURES -

- 1/3" SONY DSP Super HAD EX-View CCD
- 600TV Lines Horizontal Resolution
- Excellent Low Light Sensitivity of 0.003Lux/F2.0
- Conical Pinhole Lens 3.3mm / Angle View 130°

- * **THM-3232H** : 600TV Lines
- * **THM-3232** : 420TV Lines
- * **THM-3232X** : 420TV Lines, EX-View



1/3 SONY DSP Super HAD CCD

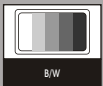

B/W



COVERT



Auto / IRIS



Flickerless

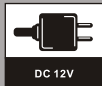

DC 12V

- DIMENSION -

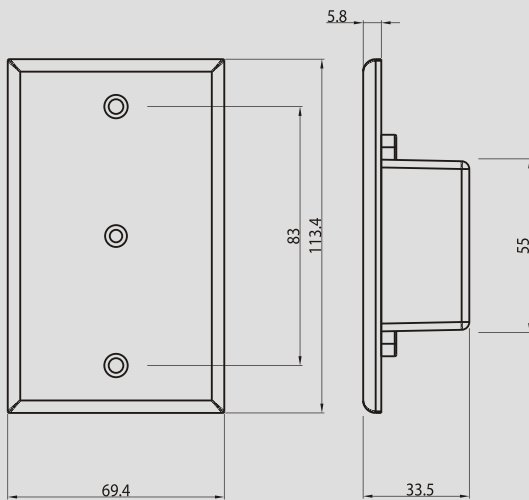

- SPECIFICATION -

THM-3232HX		
Signal Format	EIA	CCIR
Horizontal Resolution	600TV Lines	
Image Sensor	1/3" SONY DSP Super HAD EX-View CCD	
Scanning System	525 lines interlaced	625 lines interlaced
Synchronization	Internal	
Video Output	Standard composite 1Vp-p composite video into 75Ω	
Min. Illumination	0.003Lux/F2.0	
Electronic Shutter	1/60 ~ 1/100,000 sec	1/50 ~ 1/100,000 sec
Signal to Noise Ratio	45dB or more (AGC Off)	
Gamma	0.45	
AGC	On	
Lens	Conical Pinhole 3.3mm / Angle View 130°	
Input Voltage	DC12V (±10%)	
Power Consumption	Max. 140mA	
Operating Temperature	-10°C to +55°C	
Storage Temperature	-20°C to +70°C	
Operating Humidity	Under 90% Non-condensing	
Storage Humidity	Under 90% Non-condensing	
Dimension	69.4(W) x 113.4(H) x 33.5(D)mm	
Weight	76g	