

VANDAL DOME CAMERA

ZVC-32327/B36

Ø80 MINI DOME CAMERA



- FEATURES -

- 1/3" SONY Super HAD CCD
- 420TV Lines Horizontal Resolution
- Excellent Low Light Sensitivity of 0.3Lux/F1.2
- Auto White Balance
- Board Lens : 3.6mm
- Dome Size : Ø80

Option

- Wall Mount Bracket : MBR-300WM



1/3 SONY
SUPER HAD CCD



COLOR



BOARD LENS



VANDAL PROOF



DC 12V

- DIMENSION -

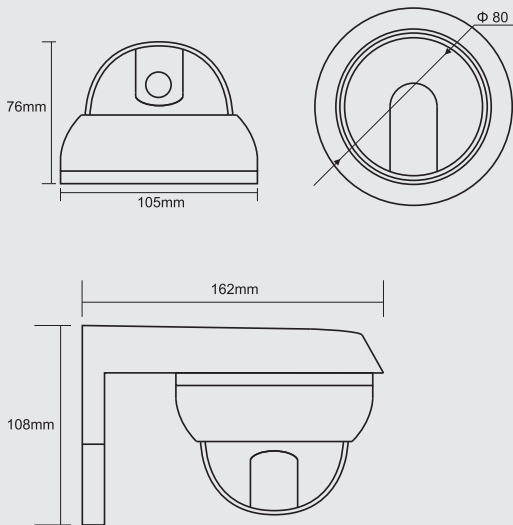

- WALL MOUNT BRACKET -



- SPECIFICATIONS -

ZVC-32327/B36		
Signal Format	NTSC	PAL
Horizontal Resolution	420TV Lines	
Image Sensor	1/3" SONY Super HAD CCD	
Effective Pixels	510(H) x 492(V)	500(H) x 582(V)
Scanning System	2:1 Interlace	
Synchronization	Internal	
Scanning Frequency	15.734 KHz(H), 59.94 Hz(V)	15.625 KHz(H), 50.00 Hz(V)
Video Output	CVBS : 1.0Vp-p/75Ω	
Min. Illumination	0.3Lux/F1.2	
Electronic Shutter	1/60 ~ 1/100,000 sec	1/50 ~ 1/100,000 sec
IRIS Control	MANUAL	
Signal to Noise Ratio	48dB or more (AGC Off)	
White Balance	AUTO	
Gain control	AUTO	
Gamma	0.45	
Lens	Board Lens : 3.6mm	
Input Voltage	DC 12V (±10%)	
Power Consumption	Max. 2.0W	
Operating Temperature	-10°C to +60°C	
Storage Temperature	-20°C to +70°C	
Operating Humidity	Under 85% Non-condensing	
Storage Humidity	Under 90% Non-condensing	
Dimension	105(Φ) x 76(H)mm	
Weight	Approx. 360g, W/Bracket : 720g	
Option	MBR-300WM	